

OPTIMIZATION COATING OF CYLINDRICAL TOOLS WITH FIXTURE FOR INCREASING MACHINE CAPACITY

TOMAS SZOTKOWSKI, IVAN MRKVICA, FILIP KOWALOVSKI

Faculty of Mechanical Engineering, VSB – Technical University of Ostrava

DOI: 10.17973/MMSJ.2020_03_2019134

tomas.szotkowski@vsb.cz, ivan.mrkvica@vsb.cz,
filip.kowalovski@vsb.cz

The coating technology is integral part of industrial production. In the tooling field, coating is an essential part. For the vast majority of tooling materials today, a coating that has abrasion resistance, high hardness, high temperature stability, as well as overall wear resistance of the cutting edge is a matter of course and necessity. However, coating machines are designed for a maximum predetermined number of tools. It would be possible to increase the capacity of the coating machine by means of a jig designed specifically for the given machine with given kinematics. The topic of this article is the design of the jig for increasing the capacity of the coating PVD machine. The main part is the design and construction of the jig, where the construction of the movement system is described. Then follows the design of the material and description of the main principle operation of the product. The jig will be designed for coating cylindrical tools, the monolithic milling cutters and drills made mostly of cemented carbide. When coating such tools with the PVD method, care must be taken to avoid so-called "shadow effects". This fact must also be reflected in the design of the fixture. Increasing the capacity of the PVD of the machine will lead to an increase in the production batch and thus an increase in profit.

KEYWORDS

Coating, PVD, fixture, capacity

1 INTRODUCTION

The increasing demand for greater flexibility in the delivery of goods and higher production volumes, with the same or higher product quality, push companies to better optimization of machines and increase their production capacities. The tool and coating industry are the same case. The research and production of machining tools is a very progressive sector of engineering industry. New cutting materials, cutting tool shapes, types of coating or modifications are introduced to the market every day, for example, the higher durability of these tools. The coating tools belong to finishing method for increase their durability, abrasion resistance and improve cutting properties. This technology works on the principle of creating a coating layer on the tool which consist of materials that are highly usable and have the required properties (abrasion resistance, heat resistance, etc.) [Zindulka 2004].

This article is focused on optimizing a machine that uses the PVD coating method. The machine structure is mostly comprised of a rotary tool holder and targets of the material that forms the coating of the tool [Humar 2008].

These components form the inner part of the coating chamber itself. Thus, the targets are electrodes that consist of the coating material. The style and number of targets is directly

depending on the required composition and complexity of the coating. The placement in the chamber which may be central (inner of the tools rotator), side (in the walls of the chamber) or a combination thereof [Humar 2008]. In practice, the more complicated the coating is the greater number of targets in the chamber see Fig. 1



Figure 1. Coating chamber

Each of these targets subsequently forms a specific layer of the resulting coating. The properties of the coating process such as stoichiometry, growth rate and roughness of individual layers, can only be altered when the targets are used by changing the current at the targets. These properties have an essential influence on the final formation of the coating and its layers (mono-, multi-, gradient) [Zlamal 2016].

In this method (PVD), the targets may be located differently in the coating chamber. The tools are located on the rotary holder mandrels and operate on the principle of planetary gearing. The entire rotary holder rotates about its axis, also the tool carrier mandrels. The last elementary movement is the rotation of the coated tool itself. This movement is necessary to coat the entire surface of the tool evenly. Planetary movement is also one of the very important aspects of the coating process, since it's necessary to synchronize the rotation of the planets on the mandrels themselves with the coating current. Tool movements around its axis are ensured by so-called kickers see Fig. 2. it's a steel part that is clamped on a rotating planet or on a fixed rotary housing structure (location depends on the diameter of the tool to be coated).

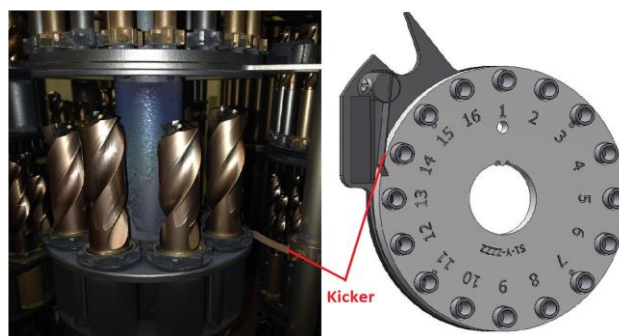

Figure 2. Kicker visualization [Oerlikon Balzers 2018]

This process must be controlled by computer systems because the planetary and current rotation settings must be very accurate. The optimized coating layer can be achieved with this setting (multi-, nano-layer) coating of 5-7 nm. Current coatings are already a combination of many layers (mono-, multi-, gradient) that are already combined according to the used substrate or tool [Mrkvica 2016].

2 PROBLEM OF EXISTING CONSTRUCTION

One of the problems of the existing design is that the placement of coated tools may arise when the capacity increase is needed. This is the so-called "shadow effect" of coated tools. This negative aspect of coating exists only in physical deposition. This effect can occur places that are covered by other components, i.e. tools, before deposited particles. In some cases, there may be a possibility that the coating may not form at all on the shadowed surfaces or cause the islet grow quicker, see Fig. 3. This phenomenon occurs especially when the coating metal particles falling on the tool surface at an angle. This particles form islets of coating behind which arise shady spot, where the coating couldn't be formed. The results are – uneven thickness of the coating and worse surface texture.

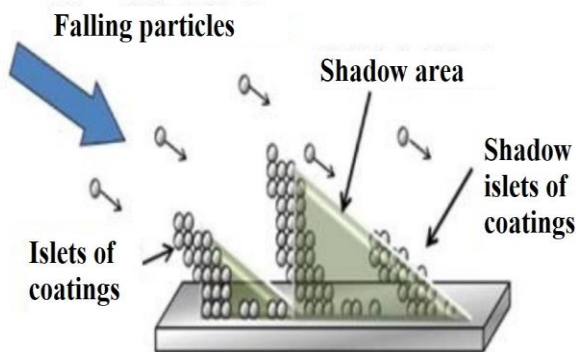

Figure 3. Principle of shadow effect [Riley 2012]

From construction point of view are the rotary housings working fine if they are for single tool. These are cylindrical tubes of a define diameter into which the coated tool is inserted. This cylindrical part serves as a cover for the clamping part of the tool. The clamping part of the tool must not be coated due to the subsequent inaccuracy of the clamping for the next coated tool. The lower part of the rotary housing is formed by a gear which is welded with a cylindrical tube on one side. However, this gearing is not normalized. Rather, it's a wheel with a tooth gap profile that follows the trajectory of the stationary kicker. It rotates the planet with the tool on that part each time the planet is rotated. A pin is formed on the gear front. This part is designed to be a negative to the holes in the planet and together with the cylindrical tube with the tool to form the planet thus the elementary part of the entire transmission see Fig. 4.



Figure 4. (From left) Rotary housing for 1 tool, rotary housings for 2 tools

A problem may arise when using a rotary hitch for two tools. In this case are the cylindrical tubes situated for the coated tools which are arranged side by side on one toothing, but in this case the rotation is only provided in the axis of the gear. Thus, the tools placed in these housings are rotated together with one side throughout the coating process. However, these tools can cause the shadow effect. These sides may be shadowed by a second tool in the rotary housings, which may result in uneven coating of both tools. The coating thickness of the two tools at the locations where they coincide with each other may be smaller and the thickness of the coating itself will not be even.

Thus, in the design of the optimization it was necessary to include not only an improvement in the form of a capacity increase of the coating machine, but a technological factor with target to the elimination of possible defects of the resulting coating.

3 CONSTRUCTION DESIGN OF OPTIMIZING PRODUCT

The optimization of the coating process consists of a jig which is constructed directly on the rotary housing of the coated objects. In this case monolithic cylindrical tools with a diameter $D = 16$ mm. The formulation was designed for the INNOVA coating machine from Oerlikon Balzers [Oerlikon Balzers 2018], which is using by Dormer Pramet s.r.o. The planet on the rotary holder for a define diameter is constructed with a maximum of 16 tools. Therefore, the use of other planets was necessary to optimize space and increase capacity. According to available dimensions and options, was selected a planet with 5 positions for tools with diameter $D = 32$ mm. see Fig. 5.



Figure 5. (From left) Planet with 16 tool positions, planet with 5 tool positions [Oerlikon Balzers 2018]

The planet for this jig was selected according to dimension usable for as many positions of coated tools as possible. The designed jig is from a constructional point of view, a simple gearbox with 4 positions for the tool see Fig. 6. Each single jig is inserted into one of the 5 positions of the selected planet. Of the lower side of the planet is a pin of diameter $D1$ that is equal to the diameter of the planetary rotary housing and manufactured with accuracy matching that housing to fix the jig to position.



Figure 6. Model of designed product

The main part of the jig is the base, which consists of a pin (designed according to the rotary housing), which is located on the underside of the base and around which is inserted into the housing to ensure rotation of one position, i.e the entire jig (Fig. 7 - bottom part of the preparation).

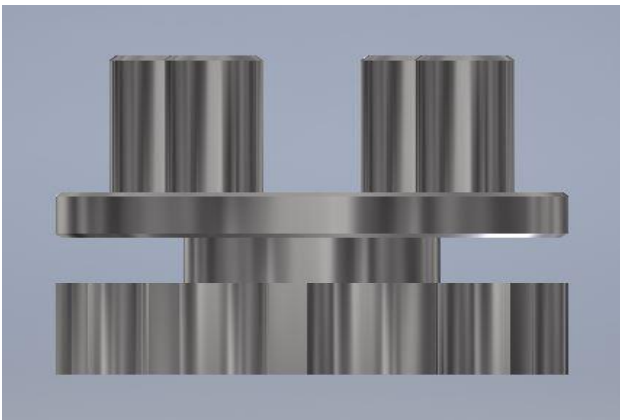

Figure 7. Lower part of the jig

A simple gear mechanism is located on this base. This is the normalized gearing with a gear ratio $i = 1$ see Fig. 8. This transmission has been designed for specific criterium for coating tools. The continuous rotation of all coated tools at the same speed are needed, also the start of rotation of coating tools on predestined position. The rotation of the tool itself by gear mechanism is initiated by a second kicker mounted on the construction of the rotary holder itself. The required movement of the individual tools is achieved by the kicker, which is one of the main criteria of the coating. The axial distance of the gears is greater than that prescribed according to the standard for the normalized gears to prevent gears from stammering. This effect could occur during observance of the prescribed axial distance due to the absence of bearings between the axis of the tool base and the gears themselves. There is a clearance $t = 1$ mm in diameter between these components. This aspect of design is necessary because of the high purchase price of

bearings that are able to operate in high-temperature areas and also because of the absence of these dimensions of bearings for this diameter (DO axis diameter = 7.8 mm).

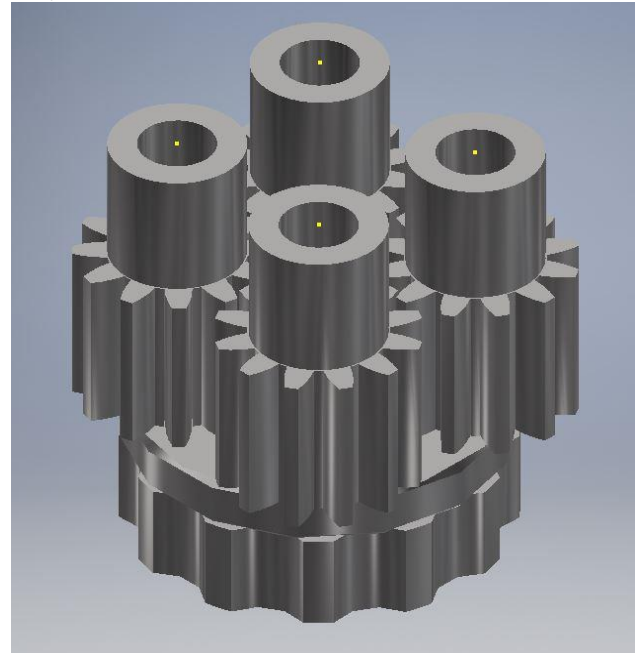

Figure 8. Planetary gear of the jig

The last part of the designed fixture are modified rotary housings see Fig. 9. The designed rotary housings consists of a pin and a cylindrical tube in which the coated tool is inserted. The cylindrical tube at the housings serve as to placing the tool and to covering of the clamping part of the tool against possible degradation of this part of the surface by coating. The housings are made precisely similar to holes in gears. Subsequently, they are pressed into the top of gears to cylindrical part without teeth. Thus, pressed housings copy rotary movement of entire gear mechanism and its possible to reach rotation of tools in rotation housing. This part of the jig is modular, because the cover of the clamping part can be extended with additional cylindrical tubes if the coating tool is longer and if required coating is only on the top of the tool as some monolithic drills, or tools with a longer clamping part.

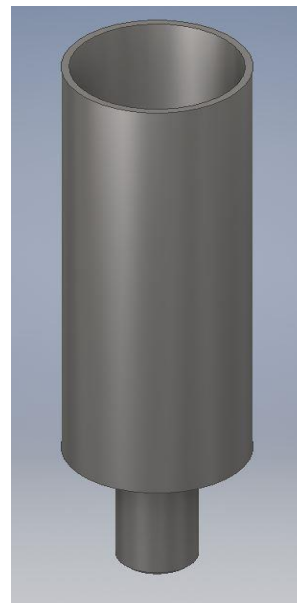

Figure 9. Rotary housing designed for jig

The all components of innovative jig needs to be made from metal which has specific required properties for PVD coating. Chromium-nickel austenitic steel to be the ideal material, i.e the so-called „food industry“ steel. It’s one of the most widespread high alloy steels with increased corrosion resistance and low carbon content. Corrosion resistance is due to the passivation ability of the steel surface (forms a protective layer). Break this layer can result in local corrosion. This steel withstands temperatures up to 350 ° C. The disadvantage of this steel is poor machinability. Each component of the designed jig must be made of this steel, because must meet the conditions of stainless steel as well as the condition of the best possible conducting of electric current for the ideal coating process.

Mechanical properties 1.4301	
	Values
Ultimate tensile strength R_m	520 – 720 N/mm ²
Yield strength R_p 0,2 min	210 N/mm ²
Ductility A 80 mm	45 %

Table 1. Mechanical properties of steel 1.4301

Chemical composition 1.4301	
Chemical element	Values [%]
C	<0,07
Si	<1,00
Mn	<2,00
P	Max. 0,045
S	Max. 0,030
N	<0,11
Cr	17,00 – 19,50
Ni	8,00 – 10,50

Table 2. Chemical composition of steel 1.4301

4 CONCLUSION

Designed to optimize the coating process for the Oerlikon Balzers machine, it’s a very good solution in terms of return the costs. From a constructional point of view, it’s an assembly of components which are made of available semi-finished products of the above-mentioned material 1.4301. From a production point of view, there are only simple machining operations. The most complicated part can be the gears. However, these parts are standardized and can be order by the manufacturer. By means of the designed construction system it’s possible to add rotation of other tools in this jig, i.e. creating other elementary planets. The great advantage of the proposed product is the elimination of the shadow effect described above. This phenomenon was eliminated by the above-mentioned addition of the gear mechanism (turning each tool separately), which was missing in the previous extension. Thus, now it’s not possible to rotating tools in the jig to create shadowed surfaces due to the added rotation of the tools about their own axis. The last modification of the machine is the addition of a secondary kicker for the rotation of the added gear of the jig. Increase the capacity of the INNOVA machine was the main idea of the optimization tool.

The rotary tool holder of the optimized machine contains 10 rotary mandrels. On each of these mandrels it’s possible to place 3 planets with 16 positions for rotary holders with tool diameter $D = 16$ mm and with 5 positions for rotary housings with diameter $D = 32$ mm for the proposed fixture. Using the tool, the 5-position planet is expanded to 20 positions for tools with a diameter of 16 mm. The result is an increase in positions on one planet by 4 places. During coating a tool and filling all positions by this type of tool, the capacity of the rotary holder with the old type planets is 480 pieces of tools per coating cycle. During using the designed construction, in the same situation, the rotary holder capacity is extend to 600 pieces of tools per coating. During using the designed jig, it’s possible to increase the capacity of the INNOVA machine up to 25% for suspension holders with tools $D = 16$ mm. In terms of effectivity it’s the increase in capacity of the machine for the tool. In future it’s possible to increase the capacity of this machine for other tool diameters by modifying the tool holders which is a huge advantage for the production and planning of production batches of companies.

Acknowledgments

Article has been done in connection with project Students Grant Competition SP2019/60 financed by the Ministry of Education, Youth and Sports and Faculty of Mechanical Engineering VŠB-TUO.

References

- [Humar 2008] Humar, A. Materials for cutting tools. Praha: MM Publishing, 2003. 978-80-254-2250-2
- [Mrkvica 1988] Mrkvica, M. Jigs and cutting tools 2nd part Jigs. 1st ed. Ostrava: VSB – Technical university of Ostrava, 1988. p. 184.
- [Mrkvica 2015] Mrkvica, I., Petru, J., Slehal. V., Neslusan, M., Jurko, J. and Panda, A. Properties of cutting inserts with different PVD coatings. *MM Science Journal*. 2015,(2), pp. 600-603. DOI: 10.17973/MMSJ.2015_06_201501. ISSN 1803-1269. Available from: <http://www.mmscience.eu/june-2015.html#201501>.
- [Mrkvica 2016] Mrkvica, I., Sleha, V., Petru, J., Neslusan, M., Jurko, J. and Panda, J. Design of control jig for inserts measurement. *Manufacturing Technology*. 2016, 16(1), pp. 198-204.
- [Mrkvica 2016] Mrkvica, I., Neslusan, M., Cep, R. and Sleha, V. Properties and comparasion of PVD coatings. *Technical Gazette*. 2016, Vol.26, No.2., pp. 569-574. ISSN 1330-3651
- [Oerlikon Balzers 2018] After Sales: Fixtures and accessories 2018. Iramali, 2018, pp. 3-66
- [Riley 2012] Riley, M., Redo-Sanchez, A., Karampourniotis, P., Plawsky, J. and Lu, T. Nanostructured porous silicon films for terahertz optics. *Nanotechnology* [online]. 2012, 23(32), [cit. 2019-10-15]. DOI: 10.1088/0957-4484/23/32/325301. ISSN 0957-4484. Available from: <http://iopscience.iop.org.ezproxy.lib.vutbr.cz/article/10.1088/0957-4484/23/32/325301/meta>
- [Zindulka 2004] Zindulka, O. Modern methods of tool coating. *MM Industrial spectrum: Trends* [online]. 2004, 13.10.2004 pp. 28 [cit. 2019-09-30]. Available from: <https://www.mmspektrum.com/clanek/moderni-metody-povlakovani-nastroju.html>
- 2005, 259(7-12), pp. 1177-1189. DOI: 10.1016/j.wear.2005.02.056. ISSN 00431648. Available from: <http://linkinghub.elsevier.com/retrieve/pii/S0043164805001602>

[Zlamal 2019] Zlamal, T., Mrkvica, I., Szotkowski, T. and Malotova, S. The influence of surface treatment of PVD coating on its quality and wear resistant. *Coatings*. 2019, Vol.9, No.7., pp. 439.

CONTACTS:

Tomas Szotkowski MSc.
Faculty of Mechanical Engineering, VSB – Technical University of Ostrava
17. listopadu 2172/15, Ostrava – Poruba 708 33, Czech Republic
+420 597 324 451, tomas.szotkowski@vsb.cz, www.fs.vsb.cz