

THE IMPACT OF CLAMPING ON THE RESULT OF MEASUREMENT OF GEOMETRIC PRECISION OF COMPONENTS

Zdenko Gunis, Augustin Gorog

Institute of Production Technologies

The Faculty of Materials Science and Technology in Trnava,
Slovak University of technology. Slovak Republic

e-mail: guniszdenko@gmail.com

The quality of cutting tools directly affects the quality of machined components. However, it can indirectly affect also the quality of components which are not machined. The errors of machined forms can be transferred to the plastic components which are produced by injection. This article deals with the flatness of groove on this kind of component which is a part of the pump on the motor vehicle. The groove has an important functional role. The control of the flatness is carried out under the conditions, which are identical to the conditions of operation – a component is in the operating conditions clamped by the screws in the exactly determined moment. Therefore, it is necessary to determine what influence has the moment of the screws on the final value of the flatness of the groove. The influence of the moment was examined in the time range from 5 to 25 Nm on the five components, which were produced by the same technology. The measurements of flatness were performed on the coordinate measuring machine.

Keywords

flatness, groove, moment, coordinate measuring machine.

1. The definition of issue

This article describes the issue related to the flatness of groove in the component which is clamped as a part of a pump, placed on the motor of vehicle. This component is made from plastic, which is marked as a PPA Grivory HTV 3H1 Black. This is a very hard plastic, which should sustain its properties while using. The component has an important role in the pump assembly and therefore it is necessary to control its characteristics of shapes and size. In this part arises the first significant problem, on this component is groove into which is inserted the rubber packing. Right here, on this groove is necessary to measure and control its flatness which must fall into the tolerance of 0.2 mm as it is required by the drawings. The flatness falls into the deviation of shape, that means, it is a deviation of the actual element from the nominal form [Ali Afjeji-Sadat 2005] Flatness has a tolerance zone, which is bounded by two parallel planes, which are distanced apart each other about the value of tolerance. The extracted (actual) surface must be located between two parallel planes, distanced apart each other by the value that is listed in the drawing documentation [ISO/TS 12781-1,2008]. This prescribed value (tolerance) is according to drawings 0.2 mm. Flatness in the groove complies the required value, control was always realised in a state when the component was not clamped and bolted to the pump. During mounting of the components to the pump, according to a defined moments there is an assumption that this flatness can change its value and can grow. During usage, this may cause the failure of pump, then the shape of groove can get worse and can leak the fluid. On this component are three bases where the component is clamped on the pump, as it is depicted on the Fig. 1. The essence of this article, will be to determine, whether the bolting

of the component to the pump, with the exactly determined moment, can cause the raise of flatness value. For the experimental part will not be used only the required moment 10 Nm, but we will observe the overall process of the flatness. It means that from the state where the component is not bolted until the moment which we can use the highest on the spanner. For making the experiment is necessary to design a meter; measurement plan, which must include the strategy of measurement and evaluation. The description of measurement plan is given in chapter 2. This issue, which is described is highly current and the training is required.

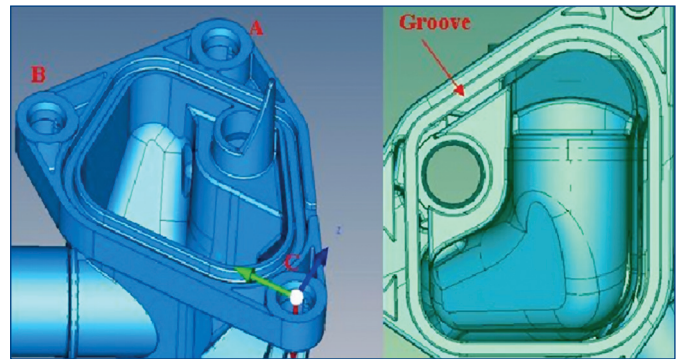

Figure 1. CAD model of the measured components.

A, B and C – clamping bases, Groove – measured groove [Calypso, 2010]

2. Draft of the experimental work

The aim of the experimental work is to determine the impact of clamping component on the flatness groove into which is inserted the rubber packing. During the measurement is not possible to use a real pump and for a simulation of the process will be used a steel plate, into which is milling the similar part, as is a real pump. This is the way, to measure the groove. (Fig. 2).

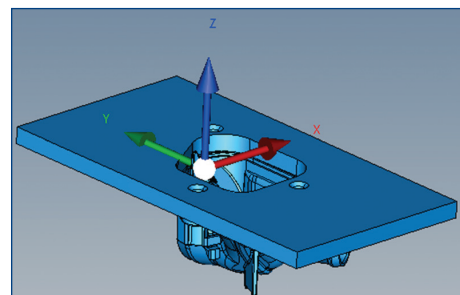

Figure 2. The component clamped on a steel plate

Practically is required that the component is clamped on the pump with the exactly set moment 10 Nm. For the accurate clamping with needed moment will be used torque wrench. In experimental work we also observe a higher application of load, as was required. It has therefore been suggested to observe the overall develop of flatness, from application of load 5 Nm to 25 Nm. Moment will be ascending for 5 Nm. Component was successively measured without clamping moment, with the clamping moment of 5 Nm, 10 Nm, 15 Nm, 20 Nm and 25 Nm. Firstly, is necessary to determine the value of flatness without clamping moment and subsequently, the component is clamped on a steel plate with screws, which are tightened with already mentioned moments. The measurement was realized for five workpieces. After first series, the component No.1 is unscrewed from the steel plate and the measuring is taken again but without clamping moment. Subsequently, the component is screwed and tightened on the steel plate with already set moments. The second series of measurements were suggested by reason of monitoring the deformation of groove after the first clamping. For this measuring

was used the coordinate measuring machine CONTURA G2 (Zeiss) of which the measurement $MPE=(1,8+L/300) \mu m$. The Calypso software 5.2.18. was used for the creation and evaluation of measurement plan. Firstly, it was necessary to create the basic coordinate system of component, according to which is the component aimed on a work table of machine. The next step was to suggest the strategy for measuring flatness of groove. It was necessary to have chosen a diameter of probe to prevent the collisions with the walls, that bound the measured flatness. For this measurement plan was used a ruby probe, its diameter is 1,5 mm. The probe was clamped in passive scanning head RDS-VAST XXT TL1. The probe was calibrated before measuring, to make sure its geometry. The next step was to design the conditions for the measurement flatness. The flatness was measured by scanning. This means, that to define the value of flatness was used a large number of points. The number of points which the groove was measured is uniform, it is 450 (Fig. 3).

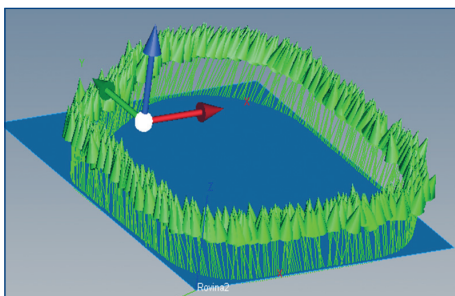

Figure 3. The points measured in groove

The speed used during the scanning was 10 mm/s. The length was 0.5 mm (Fig. 4). During the measuring the temperature was constant 20 °C.

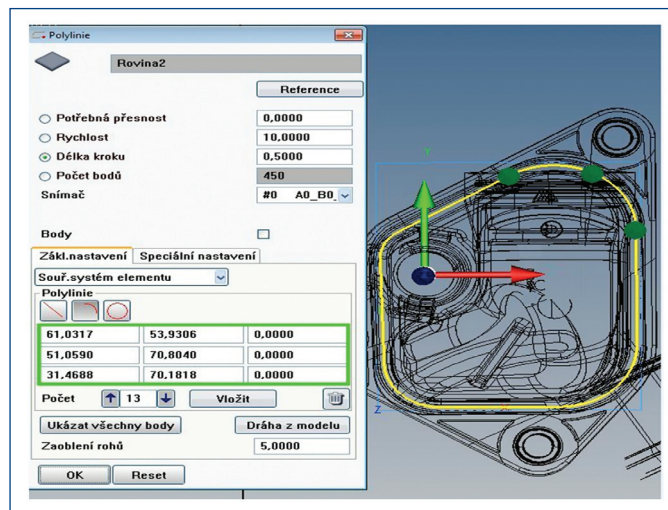

Figure 4. The conditions of measuring

The filter, used in the evaluation of measuring results is the Gaussian filter and in the evaluation process was also used the elimination of by-values. The measurement and recording of measured values was done after the creating of measurement plan. Calypso software can automatically store the measured data.

3. Measurement results and evaluation

The measurement was realized on a coordinate measuring machine CONTURA G2 under the same conditions as in the case of all five workpieces. The first measurement was carried out on the five workpieces, firstly, the each component was measured without clamping moment and then bolted to a steel plate. The measuring was accomplished gradually from tighten moment 5, 10, 15, 20 and 25 Nm. Measurement values can be seen in Tab. 1. As can be seen from the measured values, the highest value of flatness was measured in the groove without clamping moment. The average

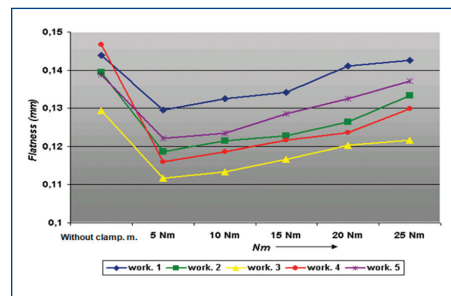

Figure 5. The course of measured values part 1–5

value of all five measurements was 0.1396 mm of flatness. The lowest measured value was accomplished when the screws were tightened by moment 5 Nm and average values of these five measurements was 0.1194 mm. This decline in the value of flatness in comparison with the value of flatness without clamping moment is approximately 15%. In these average values of flatness can be observed rise of moments over 5 Nm. The difference between 5 Nm and 10 Nm is increased by 2%, but between 5 Nm and 25 Nm is this value represents by increase 10%.

Graphic representation of measured values is on Fig. 5. The Fig. 5 depicts, that the value of flatness without clamping moment has the highest value. Subsequently, when is clamped the moment with 5 Nm, this value decreases and for all five measurements represents the lowest value. When is clamped with bigger moment, this value is growing. When is clamped the moment 25 Nm the flatness value does not exceed the measured value without clamping moment.

After this measurement, the work piece 1 was unscrewed and measured again but without clamping moment. The next measurements continued as in the first series of measurement. There was used the same measuring plan, the same conditions, for reason of observing the groove flatness deformation after the measure no. 1. All measured values are shown in Tab. 2, in which the measurement No. 1 represents the flatness value which was

Workpieces no.	Without clamping moment	Moment (5 Nm)	Moment (10 Nm)	Moment (15 Nm)	Moment (20 Nm)	Moment (25 Nm)
1	0,1387	0,1221	0,1235	0,1285	0,1325	0,1371
2	0,1439	0,1295	0,1326	0,1341	0,1415	0,1425
3	0,1394	0,1187	0,1215	0,1228	0,1264	0,1334
4	0,1294	0,1118	0,1134	0,1167	0,1203	0,1216
5	0,1467	0,1160	0,1187	0,1216	0,1237	0,1299
Average value	0,1396	0,1194	0,1219	0,1245	0,1288	0,1329

Table 1. The measured values of flatness from the part 1–5

Meas. No.	With. clamp. moment	Moment (5 Nm)	Moment (10 Nm)	Moment (15 Nm)	Moment (20 Nm)	Moment (25 Nm)
1	0,1387	0,1221	0,1235	0,1285	0,1325	0,1371
2	0,1329	0,1312	0,1352	0,1396	0,1459	0,1480

Table 2. Measured values of groove flatness in mm

measured in the first series and measurement No. 2 represents the flatness value measured after the first series of measurement.

The course of measured values can be seen in Fig. 6. The value of flatness in comparison with measure No.1 without clamping moment was reduced by value 0.0058 mm and this means the decrease of 5%. In comparison with the measured values of the first measurement, can be observed that the value after the clamping also decreased and subsequently had an increasing tendency. However, in comparison with the measured values of measurement No. 1 and No. 2 we can see that the value of flatness in 5 Nm rapidly increased and it is 7%. In comparison with the values of flatness without clamping moment in the second measurement was

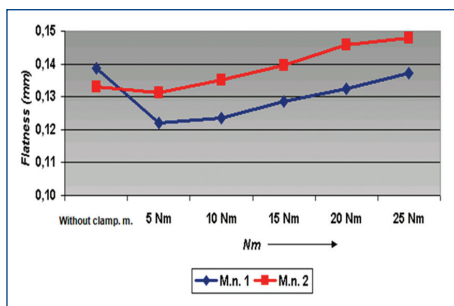

Figure 6. The comparison of the measured values of measurement No.1 and No.2

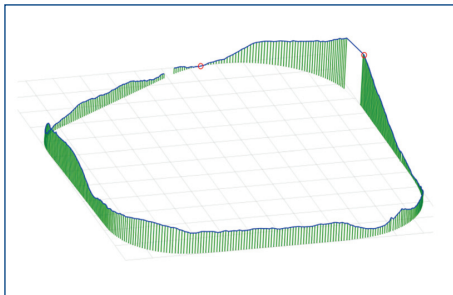

Figure 7. The flatness of the groove without clamping moment (measurement no. 1), where the red circle depicts the extreme of flatness (the highest and lowest point)

the increase of the measured values more dynamic and when it is compared without clamping moment and the clamping is 25 Nm the increase is 11%, while in first measure the increase present only 2%. The course of measured values and their comparison can be seen in Figure 6.

On the Fig. 7, we can see the flatness of the groove, where it is possible to observe the places, which depict the extremes. On the figure, the red circle depicts the highest point of flatness and lowest. This figure is created from the measurement of flatness without clamping moment in measurement no.1 part 1

4. Conclusions

This article describes the issue, which is highly actual and has a practical significance. Nowadays, the use of plastics is highly desired in industry. These plastics can undergo a heat deformation or another type of deformation and this is the reason why the plastics are very predisposed to damage. This can be avoided by constant control, which can be regarded as a feed back of improving these components chosen from plastics.

By measuring of components that are not assembled in the final composition can be prevent of damage, which may arise from the fact that this component does not have required characteristics of shape and form. Measuring of flatness in the groove shown, that the value measured without clamping moment complies the required value and is within the tolerance of 0,2 mm. The Measurement of the first series showed, that this value after the clamping of moment to the steel plate has an declining value and even with tightening moment of 25 Nm this value does not exceeded the value which was measured without clamping moment. However, the second series showed that the plastic part can be predisposed to deformation. After the measuring of flatness without clamping moment, the value of flatness with increasing tightening moment on the steel plate is changing. And with clamping moment of 25 Nm, this value exceeds the value measured without clamping moment 0,0151 mm. Very important aspect of the production of plastic parts is the quality of form in which the components are created. Under this quality can be understand the dimensional and geometric parameters with taking into consideration to the macro and microgeometry. This is given by technology production form a way of machining and cutting conditions. This includes also cutting tool as a key component of the technology system. Its quality lies in cutting materials and geometry of the cutting tool.

Article was supported by grant 1/0615/12 job Influence of 5-axis grinding parameters on shank cutter's geometric accuracy.

References

- [Ali Afjehi-Sadat 2005] Ali Afjehi-Sadat, Durakbasa, M., Osanna, H. *Technical measurement – Part II*. Vienna, Austria, 2005. ISBN 80-89112-04-8 (in Slovak)
- [Calypso 2010] CALYPSO. Carl Zeiss Industrielle Messtechnik. Oberkochen. 2010. 61212–2010512.
- [ISO/TS 12781–1 2008] ISO/TS 12781–1:2008. Geometrical product specifications (GPS) – Flatness – Part 1: Vocabulary and parameters of flatness (ISO/TS 12781–1:2003). 2008

Contacts

Ing. Zdenko Gunis, doc., Ing. Augustin Gorog PhD.
Faculty of Materials Science and Technology
Bottova 25, 917 24 Trnava, Slovak Republic
tel.: +421 902 046 969, e-mail: guniszdenko@gmail.com