

METHOD FOR PRECISE AND REPEATABLE MACHINE TOOL ADJUSTMENT ON FOUNDATION

LUKAS HAVLIK¹, LUKAS NOVOTNY², PAVEL SOUCEK²

¹Kovosvit MAS Machine Tools, corp.,
Czech Republic

²CTU in Prague, Faculty of Mechanical Engineering, Research
Center of Manufacturing Technology, Prague,
Czech Republic

DOI: 10.17973/MMSJ.2022_10_2022095

e-mail : havlik@kovosvit.cz

ABSTRACT

This article deals with placement of machine tools on a foundation. Special attention is paid to the levelling adjustment process for machines with a self-supporting frame that are free-standing on a foundation. These machines are normally placed on a foundation in a statically indeterminate way. Consequently, the machine levelling adjustment process is not repeatable. This paper presents an analysis of the current state of alignment, highlights the shortcomings of the standard alignment process and demonstrates them with measurements. The paper also presents a new method that allows alignment of the machine to the desired geometry while also ensuring a defined distribution of the machine weight, respectively the distribution of gravitational forces on the individual levelling elements (feet). The presented method uses machine alignment on so-called smart feet and subsequent unique transfer to standard feet. The method has been successfully verified in the alignment of a standard machine tool.

KEYWORDS

machine tool, foundation, levelling element, levelling adjustment, repeatable placement

1 INTRODUCTION

Placing a machine tool on a foundation means laying it freely or anchoring it to the existing floor or a separate foundation. The floor is usually made of concrete, while the foundation is made of reinforced concrete. There are adjusting elements (levelling elements) between the machine and its foundation. In some cases, the interaction at the foundation joint, i.e. the interface between the foundation and its base, is also important. An example of this would be the settlement of the foundation.

The key process of placing a machine tool on a foundation is alignment. This means aligning the machine so that its internal geometry (the relative positions during movements between the tool and workpiece) is close to the geometric ideal. This must be achieved to the degree that may be influenced by the alignment of the machine on its levelling elements.

Machine tool placement on a foundation forms a very important part of the machine installation at the customer's site. Particularly with machines with a non-self-supporting frame, this arrangement directly influences the entire range of the machine's utility characteristics, especially the static rigidity between the tool and workpiece and its modal properties. The quality of the foundation, the placement of the machine and the alignment of its internal geometry therefore affect properties

such as machine accuracy, productivity, reliability and service life.

The method of placing a machine tool on its foundation is influenced by a number of factors. One of the most important is the size and weight of the machine. This article focuses on medium-sized machine tools, i.e. machines with a maximum floor plan dimension of a few metres and a total weight of up to 20 tons. These machines are usually installed as free-standing units without anchoring to the existing floor of the production facility, using screw or wedge feet that can be adjusted in height. The placement of a machine tool on its foundation, or more generally the interaction of the machine tool with its foundation and the underlying substrate, is also addressed in the literature, e.g. [Rivin 1999], [Hazem 2003]. Machine tool feet are likewise addressed in the literature [Law 2015], [Liu 2019], as are inclination measurements (not only in the machine tool domain), see [Meier 2010], [Tsvetkov 2017], [Torng 2013], [Hun 2006]. The notion of "levelling" an object on its base is addressed in the literature [Lui 2013], [Fang 2012], [Bartkowiak 2019], [Mori 2018], [Mori 2019]. The listed publications are concerned with the machine tool industry but research from other sectors (automotive, agrotechnical, construction, aerospace) is also worth mentioning; see e.g. [Gang 2013], [Hurban 2019], [Liu 2015], [Velosa 2018], [Sun 2020], [Wang 2019a], [Chen 2020], [Wang 2019b]. Different approaches/physical principles (mechanical, hydraulic, optoelectric, etc.) are used for alignment.

In the machine tool domain, all professional publications agree that setting up the machine is one of the most important steps during installation. It is a crucial process for extremely precise machining or large machine tools. In these applications, the internal geometry of the frame may change due to the relatively higher compliance of the bed. This is mainly due to the load from the workpiece (the variability of its weight and centre of gravity position), or to the moving masses of parts of the supporting structure. The authors of the relevant articles also agree that insufficient alignment of the machine on the foundation leads in particular to a loss of machine geometric accuracy. Other consequences, such as changes in modal properties, possible reduction in service life or premature wear of certain moving parts of the machine, are also mentioned. Alignment of the machine tool on the base is usually a one-off job, where the angular deviation of reference horizontal or vertical surfaces (e.g. machine axis guide surfaces) is monitored. Machine alignment is carried out using commonly available levellers, e.g. wedge mounts levellers. In the vast majority of cases, this type of levelling depends on the experience of the staff performing it. A digital spirit level is used most often as a measuring device. A secondary reason for levelling the machine on the foundation may be the geometric inaccuracy of the machine axis guide surfaces or the imperfection of the concrete foundation surface. In some cases, the levelling process may need to be carried out much more frequently (it may be continuous in fact), often in an automated process. This applies to machines for extremely precise machining, as well as particularly large machines with long travels or machines with a large variation in workpiece weight.

The contemporary situation in common industrial practice can be summarized as follows. There is currently no sophisticated method in use for placing and aligning a machine tool on its foundation. In most cases, this process depends entirely on the experience of the workers performing it. This is especially true if the machine is mounted on more than three feet, making the machine statically indeterminate on the foundation. For machines with a relatively rigid bed, these circumstances lead to an ambiguous and non-repeatable method of placing and

aligning the machine on the foundation. Alignment of the machine, or alignment of its geometry, means levelling certain key parts of the machine, e.g. the table or the guiding surfaces of the horizontal or vertical machine axes. This is also the case when the machine axes are moving within their full stroke. At the same time, optimum and controlled force loading of each foot should also be achieved (defined distribution of the machine mass on the foundation).

The main disadvantage at present is therefore the ambiguity and non-repeatability of the process of placing and aligning the machine tool on the foundation. The solution to this deficiency is to use a more sophisticated method, where the next input variable would be the actual force loading of the individual adjustment elements (feet), and possibly also the measurement of their stroke. The motivation for the research described in this paper is to address these shortcomings.

This paper is structured as follows. In the introductory section, an analysis of the state of placement of machine tools on a foundation in a conventional adjustment process is carried out. The section includes a determination of the area of interest for a specific category of machines. A procedure for determining the optimum mass distribution of the machine on the basic feet (target condition) is discussed. For greater clarity, the proposed procedure is applied to a specific machine tool (case study 1). The results are compared to measurements of actual loads when machine placement and levelling adjustment are performed in a conventional process. The results confirm expectations about the ambiguity and non-repeatability of this machine setup. In the next part of the paper, a unique method is presented that allows alignment of the machine to the desired geometry while also ensuring a defined weight distribution of the machine on the alignment elements. The presented method has been successfully verified and demonstrated in a machine tool alignment process (case study 2). The method enables clear and repeatable placement of the machine tool on the base.

2 ANALYSIS OF MACHINE TOOL PLACEMENT USING A CONVENTIONAL ALIGNMENT PROCESS

2.1 Determining the area of interest - machine categories

This paper is primarily concerned with free-standing, medium-sized self-supporting machines with more than three feet (footings, levelling elements) on a foundation. The machines are not anchored to the foundation. The foundation is considered to be absolutely rigid and free of microscopic imperfections at the concrete grain size level. The contact of the levelling element with this foundation is therefore considered to be absolutely rigid. Macroscopic imperfections of the foundation (floor curvature, different floor heights at the leveling elements) are compensated either by a spherical surface inside the footing or by adjustment of footing height. An example of this type of machine is shown in Fig. 1. Similar machines exhibit an ambiguous and non-repeatable condition in terms of feet loading. This is especially true if the alignment of the machine on the base is carried out in a standard process, i.e. only in terms of machine geometry.

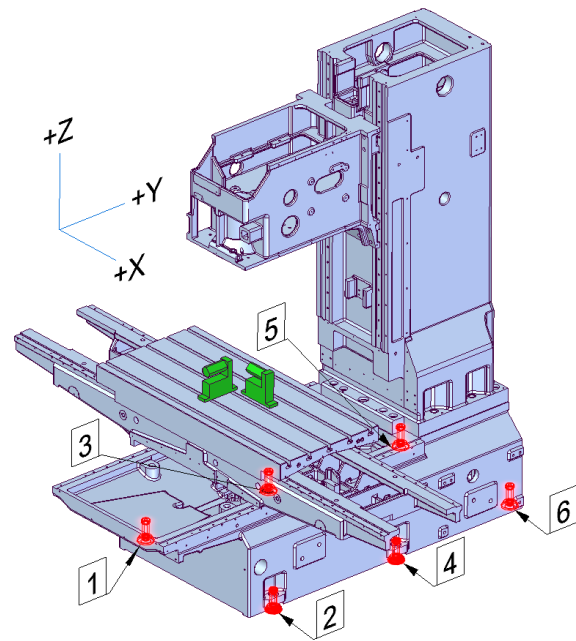

Figure 1. Sample medium-sized milling machine with self-supporting frame, placed on the foundation on 6 feet

A method of calculation (or estimation) of the optimum loading of the machine feet will be presented in this chapter. The optimum force load only applies to the corner feet (No. 1, 2, 5 and 6 in Fig. 1). The inner feet (No. 3 and 4 in Fig. 1) are used primarily to ensure straight movement of the tool or workpiece during feed axis positioning (for this category of medium-sized machines with a self-supporting frame). The inner feet therefore compensate mainly for gravitational effects or geometric machine frame inaccuracies that occur during manufacturing or assembly. Internal feet loading calculations would have to take into account the specific machining method of the individual parts of the machine frame as well as the assembly procedure. Therefore, it is preferable not to include inner feet in the basic machine mass distribution design. The machine layout under consideration without inner feet is shown in Fig. 2.

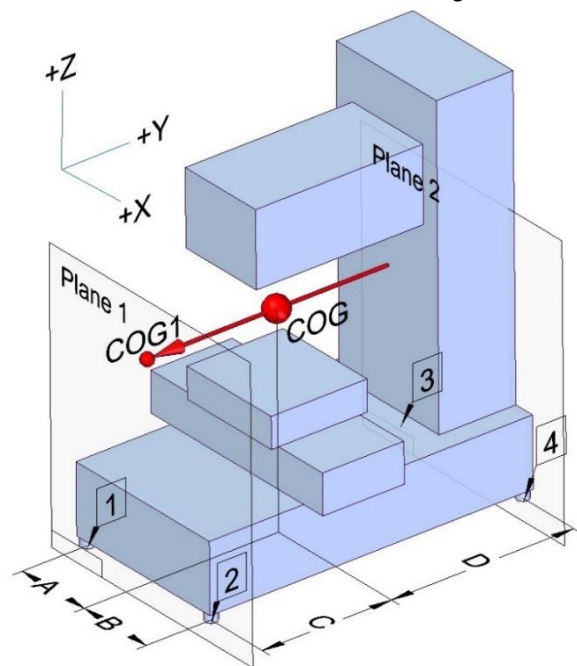

Figure 2. Considered scheme for placing the machine on 4 feet

2.2 Determining the optimal load of corner feet

Knowledge of the optimal load of each foot is necessary to ensure the correct weight distribution of the machine on the foundation. For the type and size of machines considered (Fig. 1), either moment equilibrium equations or the Finite Elements Method (FEM) can be used to determine the optimum force load on the corner feet (Fig. 2). The procedure for determining the optimum machine corner footing load is schematically indicated in Fig. 3. FEM can be used if there is a digital machine model.

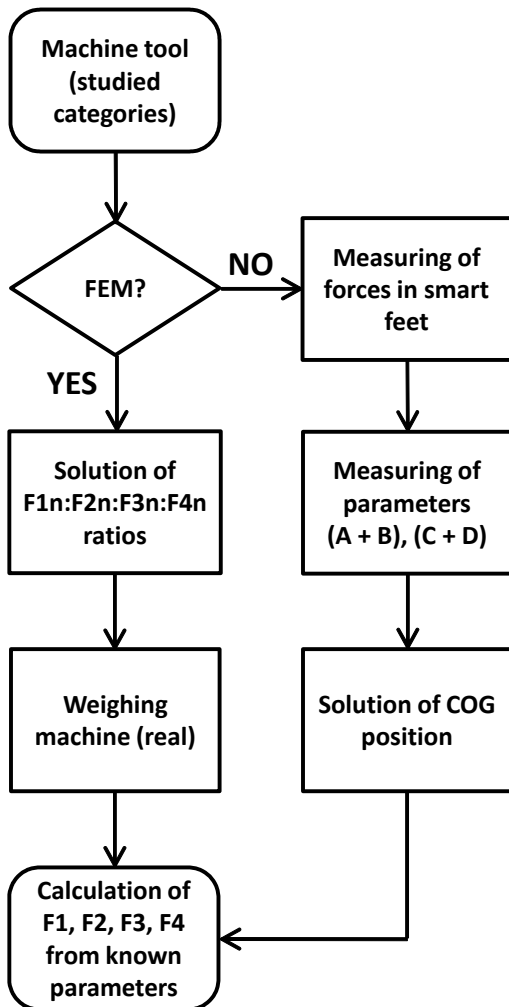

Figure 3. Procedure for determining optimal load of corner feet (see Fig. 2)

If an FEM model of the machine exists, an estimate of the forces in the corner feet can be calculated. However, the model usually does not include the machine's entire mass. Covers, aggregates, switchboards, etc. are usually missing. Therefore, the estimated forces are given with index n (as a numerical value). This permits the ratio of forces $F1n : F2n : F3n : F4n$ to be determined relatively accurately from the FEM model, but not their exact values. However, the mass of machine parts not included in the FEM model is usually distributed evenly on the machine. With some simplification, it can be assumed that it does not affect the force ratio significantly. Once the actual mass of the machine has been determined, the absolute magnitudes of the forces determined from the FEM model can be corrected to calculate the optimal values of the forces in the corner feet (F1 - F4). In practice, the actual weight of the machine can be determined, for example, by using a crane with a scale, or after loading on a truck (if a road scale is available), or by placing the machine on so-called smart feet. These will be described in Chapter 3 and

can be used even if there is no FEM model. At this point, these smart feet can be seen purely as load-measuring feet (force gauge feet).

2.3 Analytical calculation of the optimal force loading of corner feet

Moment equilibrium equations are used to determine the optimal load of the corner feet. First, the position and size of the centre of gravity (COG) must be determined. Neither the number nor the position of the feet used in this measurement has a significant effect on the determined COG position. For this measurement, the machine does not even need to be exactly aligned. For example, when the machine is placed as shown in Fig. 4, the machine lies on 3 force gauge feet (1-3) in which the load forces are measured.

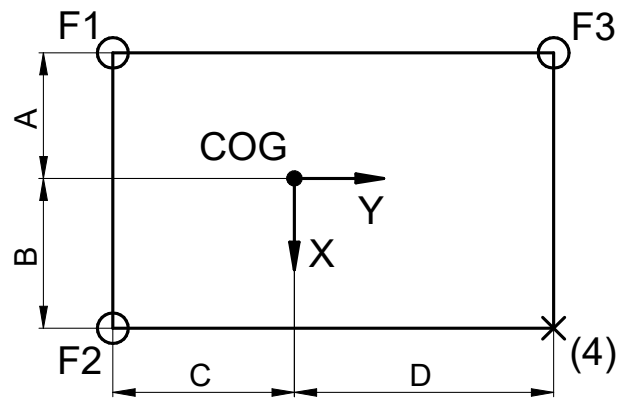

Figure 4. Scheme for determining COG (description of axes per specific machine)

Equations of moment equilibrium to X- and Y-axis:

$$X : F1C + F2C - F3D = 0 \quad (1)$$

$$Y : F1A + F3A - F2B = 0 \quad (2)$$

where F1, F2 and F3 are the reactions in the respective feet.

Since it is possible to measure the distance of the feet, i.e. the sum of A+B and C+D, the position of the COG can be calculated from equations (1) and (2). Care must be taken to ensure that the COG is within the triangle F1F2F3. In case of doubt, it is possible to activate foot 4 and adjust equations (1) and (2) accordingly. Given the resolution of the force transducer, this may have no negative effect on the accuracy of the COG position determination. When measuring forces, foot 4 is present for safety reasons but is not normally loaded.

In the next step (using Fig.2), the distribution of the weight from the COG into Plane 1 (the vertical plane passing through feet 1 and 2) and Plane 2 (the vertical plane passing through feet 3 and 4) is carried out. In this model case, the loads in COG1 and COG2 can be determined using relations (3) and (4).

$$COG1 = COG \frac{D}{C + D} [N] \quad (3)$$

$$COG2 = COG \frac{C}{C + D} [N] \quad (4)$$

The distribution of the respective parts of the machine weight (from a COG1, COG2) into the individual feet can then be determined from relations (5) to (8).

$$F1 = COG1 \frac{B}{A + B} [N] \quad (5)$$

$$F2 = COG1 \frac{A}{A + B} [N] \quad (6)$$

$$F3 = COG2 \frac{B}{A+B} [N] \quad (7)$$

$$F4 = COG2 \frac{A}{A+B} [N] \quad (8)$$

where $F1$, $F2$, $F3$ and $F4$ are the optimal reactions in the respective feet.

2.4 Calculation for a specific machine - case study 1

A medium-sized MCV-800 vertical machining centre, with an open type "C" support structure (see Fig. 1), was chosen for this case study. The machine weight is 3.3 tonnes and the stroke of the main horizontal X-axis is 800 mm. The frame is made of grey and ductile cast iron castings. The machine is equipped with six bolted support feet. The foot is equipped with a spherical surface to compensate for the angular imperfections of the foundation. The machine is not anchored; it is free-standing on the foundation. For the purpose of this case study, all feet are equipped with load cells to measure their force load, see Fig. 5. It should be noted that it should be possible to anchor even a medium-sized machine to its foundation (for the machine in case study 1 - the screw foot is hollow for possible anchor installation). However, anchoring the machine to the foundation would greatly complicate the issue addressed in this article.

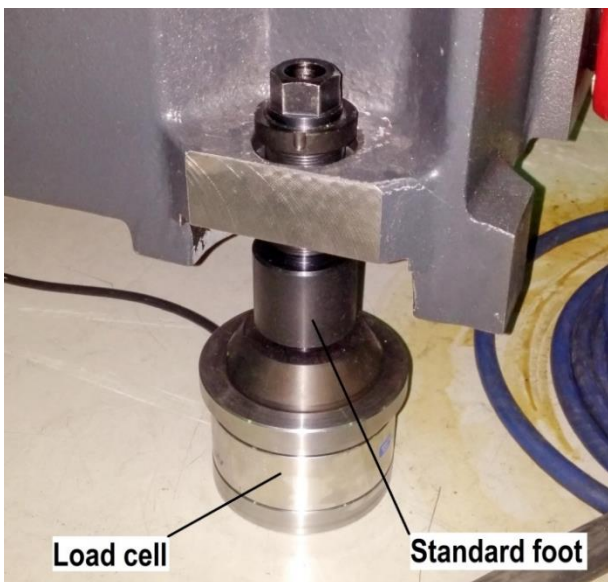

Figure 5. Standard foot with load cell

Specifically, RLC-10t-C3 load cells from Vishay Precision Group are used. Each load cell contains a full strain gauge bridge. The measurements were performed using an NI cRIO-9067 computer with NI-9237 and NI-9217 measurement modules. The LabVIEW software environment was used. The electronic inclinometers for the table tilt measurements are from Wyler (BlueLEVEL type). The inclinometers are shown in green on the machine table in Fig. 1. A schematic of the measuring apparatus is shown in Fig. 6.

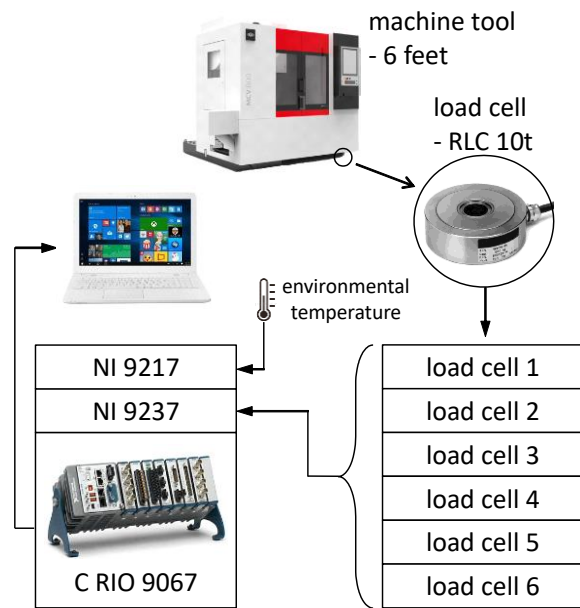

Figure 6. Measurement scheme

Analytical calculation of the optimal force loading of corner feet

The calculation is based on Fig. 1 to Fig. 4, and relations (1) to (8). For the above mentioned MCV-800 machine, $A+B = 0.49m$, $C+D = 1.282m$ (the values have been measured) and the weight of the whole machine is 32819 N. This value is the sum of the loads of the individual force gauge feet when the machine is placed according to Fig. 4 (feet 3 and 4 correspond to feet 5 and 6 according to Fig. 1):

$$\begin{aligned} F1 &= 2200 \text{ N} \\ F2 &= 18069 \text{ N} \\ F5 &= 12550 \text{ N} \\ F3 &= F4 = F6 = 0 \text{ N} \end{aligned}$$

From moment equilibrium equations (1) and (2), the position of the COG can be calculated as: $A = 0.27m$, $B = 0.22m$, $C = 0.49m$, $D = 0.792m$.

Thus, after substituting into equations (3) to (8), the optimum reactions in corner feet 3 and 4 with unloaded inner feet are:

$$\begin{aligned} F1 &= 9103 \text{ N} \\ F2 &= 11172 \text{ N} \\ F5 &= 5632 \text{ N} \\ F6 &= 6912 \text{ N} \end{aligned}$$

The analytical calculation of the optimum corner feet forces is further verified by the FEM method; see below.

Numerical calculation of the optimal force loading of corner feet

The CAD model of the frame of the tested machine is simplified and the model is meshed. All necessary boundary conditions (replacement of linear guides and ball screws, replacement of the feet, definition of limiting motion conditions, definition of gravity, etc.) are applied to this model. For the result of the force loading of the corner feet, see Fig. 7. The estimated force values are:

$$\begin{aligned} F1n &= 7593 \text{ N} \\ F2n &= 9555 \text{ N} \\ F5n &= 4984 \text{ N} \\ F6n &= 5551 \text{ N} \end{aligned}$$

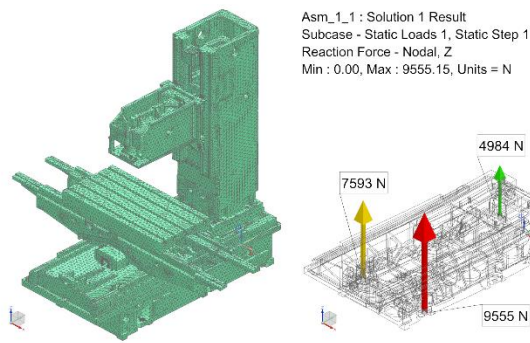

Figure 7. FEM analysis of forces in feet

It should be noted that the analytical calculation worked with the weight of the whole machine (32819 N), which in this case is approximately 1.2 times higher than in the FEM model (27683 N). The FEM model respects only the modelled mass which includes, in this case, the mass of the frame and several dominant parts of the machine (gearbox, tool magazine, spindle, etc.). For example, the mass of enclosures, wiring, liquid fillings, etc. is neglected. Knowing the ratio between the actual weight and the FEM model weight ($i = 1.1855$), the FEM method gives the following optimal forces in the corner feet:

- F1n' = 9002 N
- F2n' = 11328 N
- F5n' = 5909 N
- F6n' = 6580 N

The comparison shows that both approaches (analytical and numerical) yield similar results and therefore both are applicable to practice. The FEM model will probably give less accurate values in this case, but its error is still acceptable in practice (the deviations between the actual forces and the optimal forces, with the standard machine placement process, are large – see the next section).

In addition, it should be noted that a FEM calculation including the internal feet (numbers 3 and 4 in Fig. 1) would give incorrect results. As these feet are closest to the centre of gravity of the machine, they would naturally be loaded the most. However, this is not normally the case in practice.

2.5 Measurement of the force load on the feet during standard machine alignment - case study 1

The initial condition of the experimental alignment is the intentional placement of the machine on only three corner feet (statically determinate placement). These feet were chosen randomly, and the chosen initial feet were changed for the each repetition of the experiments. Even this extreme case (initial support on only three feet) is possible in practice.

The levelling alignment of the machine follows a standardized procedure. The aim is to achieve the best possible table level, at least according to the requirements of ISO 10791-2 (position G4 and G5), i.e. within an inclination tolerance of 60 $\mu\text{m}/\text{m}$. The level measurement is carried out using two electronic spirit levels placed on the table (perpendicular to each other, shown in green in Fig. 1). All machine axes are at the centre of their strokes and are standstill. The adjustment of the height of each foot is based on the experience of the operators. First, the machine is placed on all corner feet (feet 1, 2, 5 and 6), i.e. in this case, foot 5 is "activated". Once the table has reached the best possible degree of levelling (at least in terms of ISO requirements), the axes (here the Y-axis) start to move and the inner feet (feet 3 and 4) are activated. By adjusting primarily these inner feet, the table nivell level spread is minimized. The

force load on the feet is not monitored in this conventional machine alignment method. For this reason, the measurement of the force load of each foot is not visible to the operator during the entire levelling process. The time course of the machine levelling alignment is shown in Fig. 8. The numbers of the feet in the graph correspond to the labels in Fig. 1.

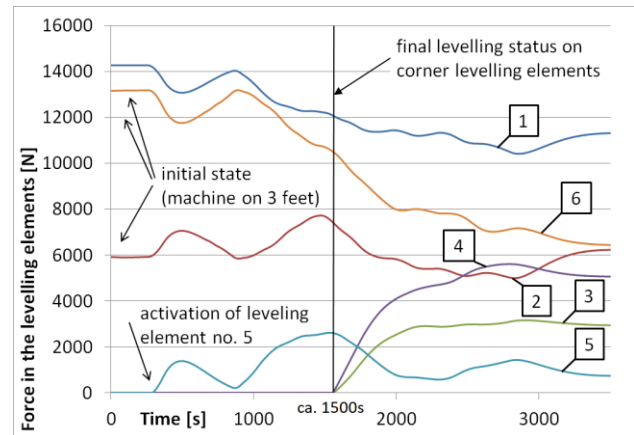

Figure 8. Machine tool alignment process

Before the start of the travel in the Y-axis, i.e. before the activation of the inner feet (time approx. 1500 s in Fig. 8), the table nivell level (its inclination) was less than 1 $\mu\text{m}/\text{m}$. The actual load values and their comparison with the optimum forces according to the calculation are summarized in Table 1.

	Optimal [N]	Measured [N]	Difference [N]	Difference [%]
F1	9103	12100	2997	33
F2	11172	7450	-3722	-33
F5	5632	2600	-3032	-54
F6	6912	10500	3588	52

Table 1. Table of corner feet loads. The values of optimal loads, measured loads and their differences compared to the optimal values are given. The values are without the involvement of the inner feet (No. 3 and 4 in Fig. 1).

Table 1 shows the discrepancy between the analytical prediction and the actual results in a standard machine adjustment process. In the final state of alignment on 6 feet, the table was aligned within an inclination tolerance of 22 $\mu\text{m}/\text{m}$, i.e. within the allowable tolerance of the relevant standard. However, the load distribution was found to be extremely uneven across the feet. The ratio between the most loaded foot (No. 1) and the least loaded foot (No. 5) is greater than 10.

This measurement was repeated several times. The initial conditions, e.g. the number and selection of the feet used for the initial state of the machine, were also varied. The results of all measurements are very similar in terms of uneven load distribution among the feet. Some feet were always overloaded and some were only minimally loaded.

The consequences of such an uneven distribution of forces are both an overloaded foot and an underloaded foot, which may even become detached from the foundation during machine operation. This effect was also achieved during the experiment where the feet load was measured during the machine's emergency stop (as shown in Fig. 9 - red circle).

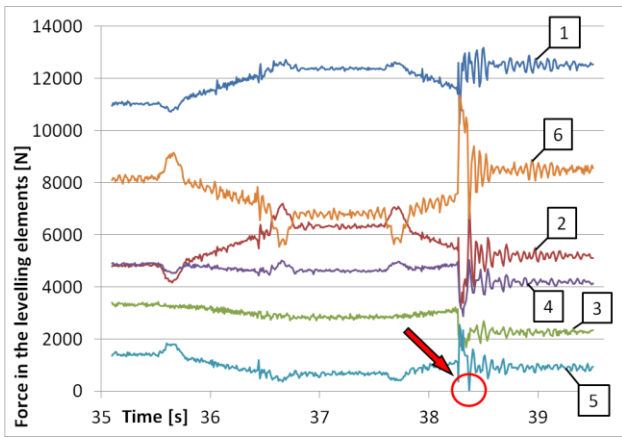

Figure 9. Loss of contact between the foot and the floor during machine's emergency stop (rapid traverse in Y-axis)

In this experiment requirements close to the velocity setpoint step of all three machine axes are met. Technically, they are implemented by activating the Central Stop during the rapid traverse of a given axis. Fig. 9 shows, for example, the Y-axis emergency stopping process with dynamic forces in each footing, including the short-term loss of contact between one of the feet and the foundation (marked in the figure). The emergency stop was always activated in the middle of the stroke of the respective axis. Measurements were taken several times, for all three axes, for both stroke directions.

Further aggravation of the uneven distribution of forces among the feet is caused by the travel of the machine axes. This causes a change in the position of the COG. The situation is illustrated in Fig. 10. Here the travel of the table is shown in the horizontal plane, i.e. in the XY plane.

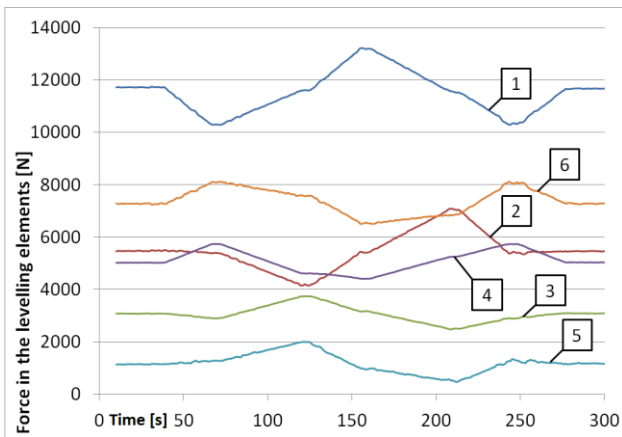

Figure 10. Changing of forces in footings by stroke of the machine axis

2.6 Partial summary of the standard machine alignment process

Statically indeterminate machine placement may be inadequate when the machine is aligned in a standard way. Alignment based on knowledge of the geometry (table level) alone and without knowledge of the magnitude of the forces in each foot can be considered a conventional (standard) method. The actual values of the load on each foot may differ significantly from the expected values in this alignment method. Some of the feet may be overloaded, while others may be almost unused. Various problems can then occur during machine operation, such as loss of contact between the feet and the foundation. Some machine parameters (e.g. stiffness within the working space) are not

given unambiguously and repeatably due to the machine placement. These observations are confirmed by case study 1. A proposal for a possible solution is described in the following chapter.

3 CONCEPT OF MACHINE ALIGNMENT USING SMART FEET

3.1 Basic description of the solution

As already mentioned, repeatable and unambiguous placement of the machine on the foundation is simply not possible if the force load data of each foot is not available. Standard, commercially available feet do not normally have force load measurements. These feet would be excessively expensive for normal machine operation. The force measuring gauge would only be used during the machine placement and alignment process. Further complications (technical and financial) would be the transfer of data from the feet to the measuring unit, power supply to the feet, ensuring the robustness of the feet – overload, shock, degree of protection, etc. For all of these reasons, it is advantageous to use standard feet for permanent (final) machine installation. Exceptions are made for very precise or very large machine tools, which are not the subject of this study.

This summary leads to two requirements: measuring the loading of the feet during machine alignment and implementing the final installation of the machine on standard feet. The authors of this paper propose solving the problem by temporarily using two sets of feet. The first set consists of standard feet placed in permanent (final) machine bed locations. The second set of feet consists of more sophisticated force gauge feet ("smart feet") placed in close proximity to the standard feet. The machine bed must be prepared for this 'double' placement. It must have machined and sufficiently load-bearing surfaces close to the standard feet locations which can be used to set the machine on the smart feet. Alignment of the machine on the foundation then takes place only on these smart feet. Therefore, each smart foot is also equipped with a mechanism (or actuator) for adjustment of its stroke level. And it is also equipped with a sensor of the actual stroke, i.e. a contact or non-contact measurement of the vertical distance of the bed (close to the foot) from the ground, see Fig. 11.

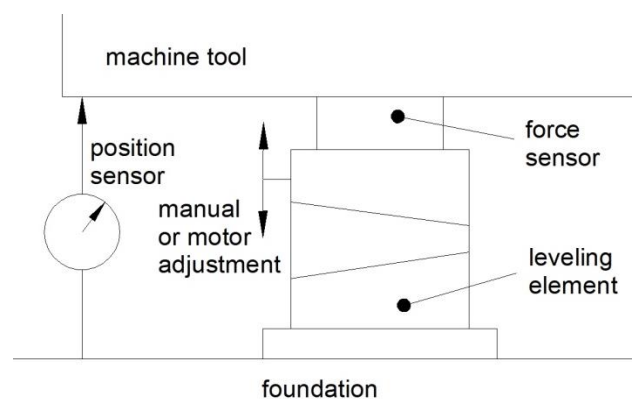

Figure 11. Scheme of the smart foot

The reason for measuring the change in bed-to-ground distance is the use of a unique method of transferring the aligned machine from the smart feet to the standard feet, without significantly disturbing the machine geometry and without fundamentally changing the force load at each foot location. This article presents only the smart foot concept and its use in machine alignment. For the purpose of verifying this concept, the use of a standard adjustable foot with an additional force

gauge and external position measurement is fully sufficient. The design of the smart foot prototype is not directly addressed by the authors of the article. It will be the subject of further work.

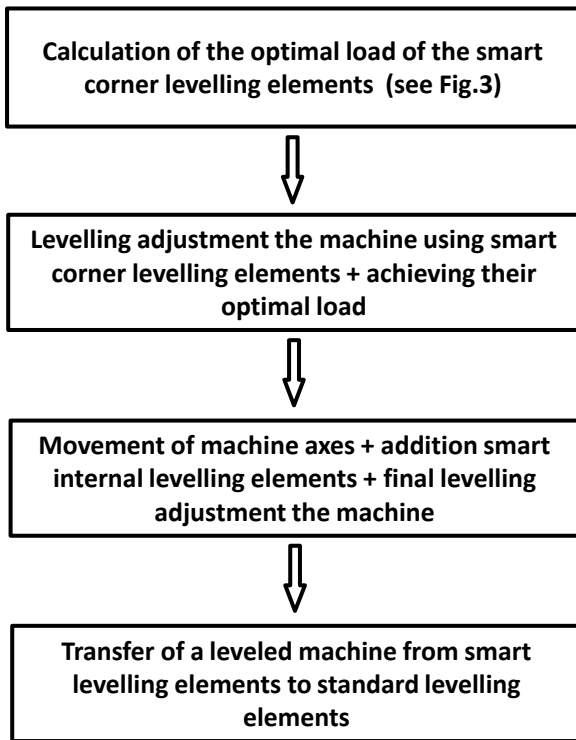

Figure 12. Machine adjustment procedure using smart feet

The machine adjustment procedure using the smart feet is described by the block diagram in Fig. 12. In the first step, the optimal load of the corner feet is calculated using one of the methods described above. This load should be achieved in the next step as shown in Fig. 12. The result is a machine aligned to the correct geometry and at the same time with the correct distribution of forces at each alignment location. In the third step, the machine axes start to move and the internal smart feet, which have been lightened up to this time, are activated. These take on part of the machine's weight and ensure that the machine maintains its correct geometry even when positioning the machine axes. The result of this step is a fully aligned machine with a clearly defined and repeatable placement which, however, stands on smart feet. In the last step, the machine is transferred to standard feet in a defined process. The result is a fully aligned machine on standard feet that retains the weight distribution defined by the previous procedure. The block diagram in Fig. 12 is illustrated by a real example in the following section (3.2).

3.2 Experimental validation of the machine alignment method using smart feet - case study 2

Verification of the machine alignment method using smart feet with subsequent transfer to standard feet as described above will be presented in this chapter. All of the following experiments were carried out on a MCV-1016 machine. This machine has an identical concept to the one used in case study 1 (MCV-800) but is larger in size. The stroke of the main horizontal X-axis is 1016 mm and the weight of the machine is 5 tonnes. The reason for this change was that the original smaller machine was not available for subsequent experiments.

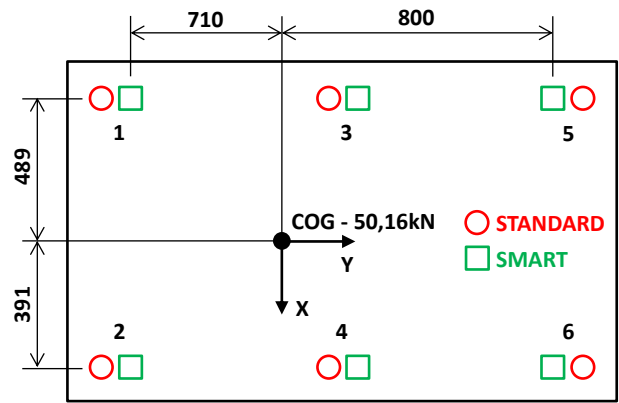

Figure 13. Scheme of the MCV-1016 machine feet locations

All relevant data for the calculation according to Chapter 2 is shown in Fig. 13. It shows the positions of the standard and smart feet, as well as the position of the COG. This COG position was determined from equations (1) and (2) in Section 2.3. Subsequently, the optimal forces in the corner smart feet were determined from equations (3) to (8) in Section 2.3:

$$\begin{aligned}
 F_1 &= 11799 \text{ N (tolerance } \pm 10\%: 10620 - 12980\text{N)} \\
 F_2 &= 14767 \text{ N (tolerance } \pm 10\%: 13290 - 16240\text{N)} \\
 F_5 &= 10477 \text{ N (tolerance } \pm 10\%: 9430 - 11520\text{N)} \\
 F_6 &= 13112 \text{ N (tolerance } \pm 10\%: 11800 - 14420\text{N)}
 \end{aligned}$$

The force tolerance of $\pm 10\%$ is an engineering estimate of the appropriate size of this tolerance considering the actual technical equipment used to set this force.

Fig. 14 shows a standard foot (left) and the smart foot (right). The standard foot consists of a conventional screw foot, made by the machine tool manufacturer itself. The smart foot is based on a wedge, a commercially available foot (DKP-2/10, Nivell). Both feet have manual height adjustment, controlled by an operator. For a more advanced version of the smart foot, the lifting mechanism could be replaced by, for example, a hydraulic or electromechanical actuator. Hydraulics would also have the advantage of being able to measure the load force directly via pressure. For the purpose of the verification experiment, the smart foot was equipped with a force measuring gauge (the aforementioned RLC-10t-C3). A contact inductive position sensor with a resolution of $0.1 \mu\text{m}$ (Millimar 1240, Mahr) was used to measure the change in the distance of the bed (at the location of this pair of feet) from the ground, see Fig. 15. The electronic inclinometers, software environment, measuring apparatus and its schematic are the same as in case study 1.



Figure 14. Standard foot (left) and the smart foot (right)



Figure 15. Measuring the vertical distance of the bed from the foundation

In case study 2, the standard foot is placed on an auxiliary support (roller, see Fig. 14). This is due to the great height of the (improvised) smart foot. For real deployment of the smart foot, completely new development of the foot is expected. The main requirements for it are low height (for the lack of auxiliary support of standard feet), force measurement (at least half of the machine weight), actual stroke measurement (with accuracy in microns), height adjustability (in millimetres), overload capacity (at least 150% without damage), sufficient degree of protection, etc.

During machine alignment, all standard feet are completely lightened and the machine alignment on the foundation takes place first only on the corner smart feet. In this study, these are feet 1, 2, 5 and 6 (see Fig. 1 and Fig. 13). The levelling is carried out not only with respect to the table nivell level (in compliance with ISO 10791-2) but also with respect to the optimal force load on these corner feet. At this stage the table is not moved, all axes are standstill, in the middle of their strokes.

Figures 16 and 17 show the machine alignment in terms of the table nivell level (Wylér electronic inclinometers) and the optimal force load on the corner feet (LabVIEW measurements).

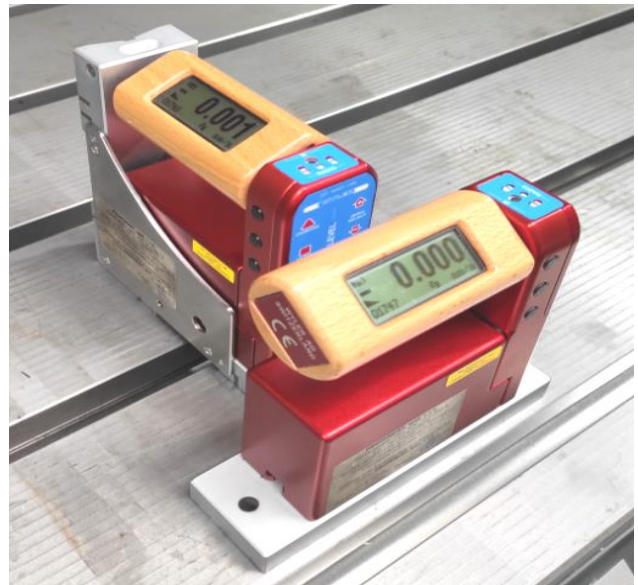

Figure 16. Reaching table levelness

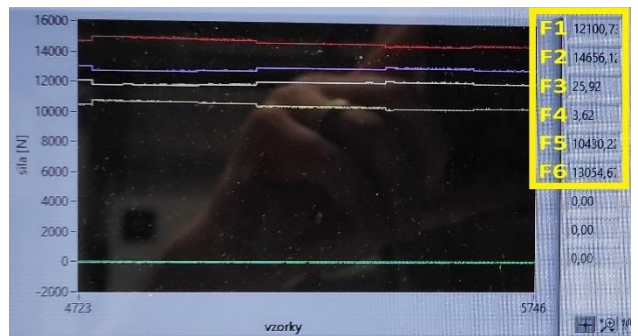

Figure 17. Reaching optimal forces in the corner levelling elements

When the machine reaches the required alignment, it starts to move with the table, and the internal smart feet are then activated (in this case study these are feet 3 and 4). The final machine alignment, i.e. achieving the smallest possible tolerance of the table inclination during the stroke of the machine axes, is done by adjusting primarily the height of the internal feet. This naturally changes the load on the corner feet. However, this load on each foot is quite uniform, as shown in Fig. 18 (cf. Fig. 8).

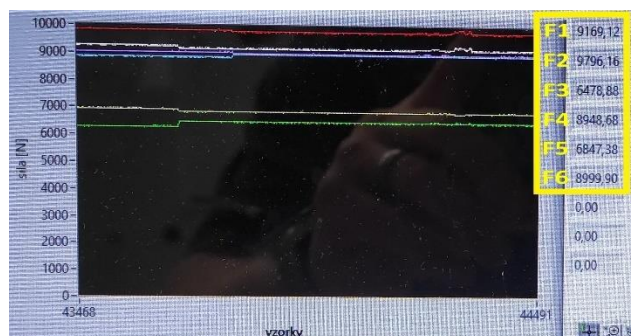

Figure 18. Final forces in levelling elements

As a final step in the machine alignment process, a unique transfer from the smart (but expensive) feet to the standard feet will take place. The assumption of this transfer is that the smart feet are in close proximity to the standard feet. That is, the stiffness of the setting area is extremely high. The setting area is the part of the bed between a particular smart foot and standard

foot. Another assumption of the transfer is that the state of the machine before the transfer (i.e. the state of its alignment and the distribution of forces in each foot) is determined only by the position of these setting areas in space or rather their height above the ground. The actual procedure of transferring each smart foot to a standard foot is schematically outlined in four steps in Fig. 19.

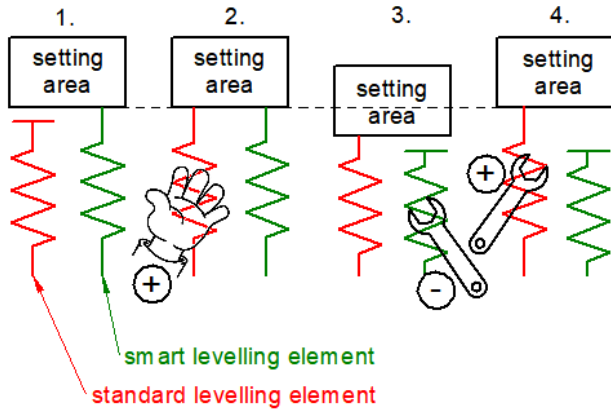

Figure 19. Process of transferring the machine from smart feet to standard feet

The setting areas are transferred one by one. Before the transfer starts, the vertical distance of the bed setting area from the ground is recorded. The standard foot (still fully lightened, see Fig. 19-1) is manually tightened just to reach the contact with the bed (see Fig. 19-2). The smart foot is then fully lightened (see Fig. 19-3). Within the flexibility of the whole system, the bed (respectively the specific setting area) drops locally. Then the standard foot is tightened so that the bed setting area reaches its original distance from the ground (see Fig. 19-4). This procedure avoids the negative effect of hysteresis (when tightening and loosening the thread). Two typical transfers of the entire machine are shown in Fig. 20 and 21.

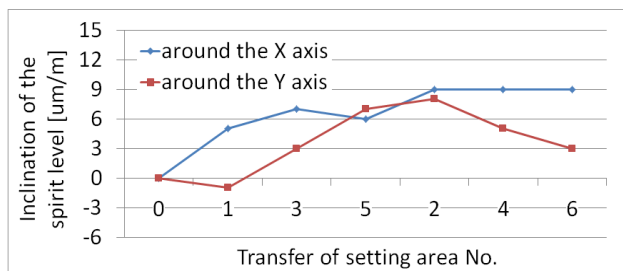

Figure 20. Final transfer of the levelled machine from smart feet to standard feet (experiment 1)

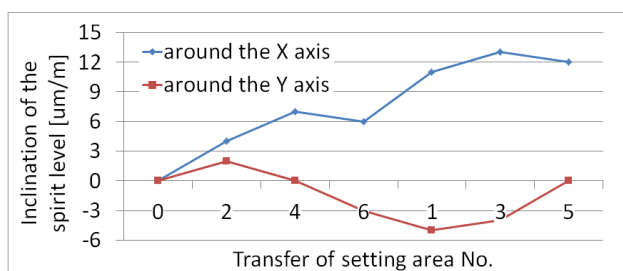

Figure 21. Final transfer of the levelled machine from smart feet to standard feet (experiment 2)

Before starting the machine transfer (i.e. all six setting areas), both spirit levels on the table are switched to relative mode and

reset (= setting area No. 0 as X-axis in Figs. 20 and 21). Each setting area (= setting areas No. 1 - 6) are then transferred in the above-described process, deliberately in different orders; see X-axes in the figures. These figures show the inclination of the machine table around the X- and Y-axes each time the setting area is transferred. The result of transferring the aligned machine from smart feet to standard feet is an inclination of 9um/m around the X-axis and 3um/m around the Y-axis (for the transfer in Fig. 20), respectively 12um/m around the X-axis and 0um/m around the Y-axis (for the transfer in Fig. 21).

It should be noted that the ISO 10791-2 standard allows a table inclination within a tolerance of 60um/m for the type and size of machine used in the previous experiments. The machine manufacturer's internal standard is half of this value, i.e. 30um/m. It should also be noted that the transfers shown in Figures 20 and 21 were some of several performed. A total of 6 machine transfer repetitions were performed, with the tolerance of the final table inclination achieved within one half of the machine manufacturer's internal standard (i.e. within 15um/m).

3.3 Partial summary of the machine alignment in a repeatable process

The presented machine alignment method in a repeatable process works with knowledge of the forces in the levelling elements in addition to the machine geometry (table horizontality). Since the optimal size of the forces is also known and the machine alignment is carried out with this in mind, the machine alignment is unambiguous and therefore repeatable. At the end of the chapter, a unique method of transferring the aligned machine from expensive smart feet to standard feet is presented, without significant disturbance of the machine geometry or a fundamental change in the force loading of any of the machine levelling elements. An example showing the change in the force load on the feet when transferring, for example, foot No. 6 during one of the experiments described above, is shown in Fig. 22.

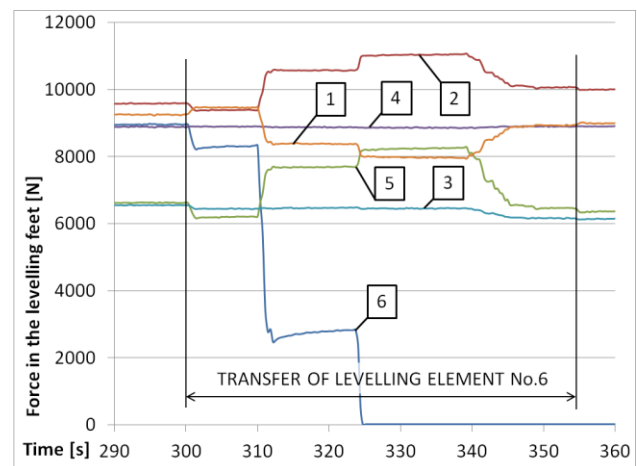

Figure 22. Force during the transfer of levelling element No.6

In a time of approx. 300s, standard foot No. 6 is tightened manually (cf. Fig. 19-2; smart foot No. 6 detects the drop in transmitted force). At a time of 310s, smart foot No. 6 is released (cf. Fig. 19-3). The delay at 325s is only the technical need for the entire loosening of this foot (key manipulation). By time approx. 355s, the given bed setting area is returned to its original height above the ground by lifting the standard foot (cf. Fig. 19-4).

4 CONCLUSION

This article deals with machine tool alignment on a foundation. The specific focus is on medium-sized machines that are free-standing on a foundation, with a self-supporting frame using more than three support feet. This involves placing the machine in a statically indeterminate process. In standard machine adjustment, this leads to an ambiguous and non-repeatable distribution of the machine weight among the feet.

In the introductory section of the paper, a rather detailed overview of the issues in machine placement is presented. Currently, no sophisticated method is used in the process of placing and aligning the machine tool on a foundation. In most cases, this process depends entirely on the experience of the workers performing it.

For a given target category of machines, the paper further presents an analysis of the machine tool placement condition when the levelling adjustment is performed in a conventional process. A procedure for determining the optimum distribution of the machine's gravitational forces on the base feet was defined (target condition for the corner feet). For illustration, the procedure is further applied to a specific machine tool. In case study 1, measurement of the conventional alignment condition of the MCV-800 was carried out. The results of the calculation of the optimal feet loads are compared with measurement of the actual loads when the machine is aligned in a standard manner. The results confirm the expectation of the ambiguity and non-repeatability of such a machine alignment.

The next section of the paper presents a method that allows alignment of the machine to the desired geometry and at the same time ensures a defined distribution of the machine weight, respectively the distribution of gravitational forces on the individual levelling elements (feet).

Thanks to this procedure, an unambiguous and repeatable alignment of the machine tool on a foundation can be achieved. The presented method is based on aligning the machine in a defined process on a set of smart feet and then uniquely transferring the aligned machine to standard feet. This is done without any significant disturbance to the machine geometry or force distribution among the feet, which has been verified through experiments. The described solution uses a design concept based on smart feet. Design of this element is not a direct part of this paper, but is the subject of future work.

ACKNOWLEDGMENTS

This work was supported by the Grant Agency of the Czech Technical University in Prague, grant no. SGS22/159/OHK2/3T/12.

REFERENCES

- [Bartkowiak 2019] Bartkowiak, Tomasz, et al. A design of an automated compact positioning system for workpiece positioning in machine tool workspace. *Procedia CIRP*, 2019, Vol.81, pp 186-191. ISSN 2212-8271
- [Chen 2020] Chen, Ruchen, et al. Simulation Analysis of a Self-balancing Hydraulic Platform for Agricultural Machinery in Mountainous Regions. *Journal European des Systemes Automatisés*, April 2020, Vol. 53, No. 2, pp 203-211. ISSN 2116-7087
- [Fang 2012] Fang, Suping, et al. An automatic leveling method for the stage of precision machining center. *The International Journal of Advanced Manufacturing Technology*, July 2012, Vol. 61, pp 303-309. ISSN 1433-3015
- [Gang 2013] Gang, Xianyue, et al. Optimal load balancing leveling method for multi-leg flexible platforms. *Chinese Journal*

of Mechanical Engineering, September 2013, Vol. 26, pp 900-908. ISSN 2192-8258

[Hazem 2003] Hazem Elsayed El-Shourbagy, available from <http://osp.mans.edu.eg/s-hazem/Mtdr/MTD02-1.html>

[Hun 2006] Hun, Jeong, et al. Estimation of machine tool feed drive inclination from current measurements and a mathematical model. *International Journal of Machine Tools and Manufacture*, October 2006, Vol. 46, No. 12-13, pp 1343-1349. ISSN 0890-6955

[Hurban 2019] Hurban, Milan, et al. Automated Tripod Leveling and Parameter Estimation for a Granular-fill Insulation Distributing Robot. *IFAC-PapersOnLine*, 2019, Vol. 52, No. 15, pp 223-228. ISSN 2405-8963

[Law 2015] Law, M., et al. Active vibration isolation of machine tools using an electro-hydraulic actuator. *CIRP Journal of Manufacturing Science and Technology*, August 2015, Vol. 10, pp 36-48. ISSN 1755-5817

[Liu 2013] Liu, Yongsheng, et al. Simulation and research on the automatic leveling of a precision stage. *Computer-Aided Design*, March 2013, Vol. 45, No. 3, pp 717-722. ISSN 0010-4485

[Liu 2015] Liu, Zhenting, et al. Automatic Leveling System of Precision and Heavy Load Platform. In: *International Conference on Management, Computer and Education Informatization*, 2015, pp 94-97

[Liu 2019] Liu, Haibo, et al. Pretightening sequence planning of anchor bolts based on structure uniform deformation for large CNC machine tools. *International Journal of Machine Tools and Manufacture*, January 2019, Vol. 136, pp 1-18. ISSN 0890-6955

[Meier 2010] Meier, Edi, et al. Hydrostatic levelling systems: Measuring at the system limits. *Journal of Applied Geodesy*, September 2010, Vol. 4, No .2, pp 91-102

[Mori 2018] Mori, Kotaro, et al. Implementation of jack bolts with built-in preload sensors for level condition monitoring of machine tool. *Procedia CIRP*, 2018, Vol. 77, pp 509-512. ISSN 2212-8271

[Mori 2019] Mori, Kotaro, et al. A robust level error estimation method for machine tool installation. *Precision Engineering*, July 2019, Vol. 58, pp 70-76. ISSN 0141-6359

[Rivin 1999] Rivin, Eugene. *Stiffness and damping in mechanical design*. Detroit: Marcel Dekker Inc., 1999. ISBN 0-8247-1722-8

[Sun 2020] Sun, Yixin, et al. Development of a four-point adjustable lifting crawler chassis and experiments in a combine harvester. *Computers and Electronics in Agriculture*, June 2020, Vol. 173, p. 105416. ISSN 0168-1699

[Torng 2013] Torng, Jingsyan, et al. A novel dual-axis optoelectronic level with refraction principle. *Measurement Science and Technology*, February 2013, Vol. 24, No. 3, p. 035902.

[Tsvetkov 2017] Tsvetkov, R. V., et al. Numerical estimation of various influence factors on a multipoint hydrostatic leveling system. *IOP Conference Series: Materials Science and Engineering*, February 2017, Vol. 208, p. 012046

[Velosa 2018] Velosa, C., et al. Automatic Leveling of a Platform to Achieve Artificial Gravity. In: *Proceedings of the 14th International Symposium on Artificial Intelligence, Robotics and Automation in Space*, 2018

[Wang 2019a] Wang, Zhuangzhuang, et al. Development of an agricultural vehicle levelling system based on rapid active levelling. *Biosystems Engineering*, October 2019, Vol. 186, pp 337-348. ISSN 1537-5110

[Wang 2019b] Wang, Zhongshan, et al. Model establishment of body attitude adjustment system based on Backstepping control algorithm and automatic leveling technology. *Cluster Computing*, March 2019, Vol. 22, pp 14327-14337. ISSN1573-7543

CONTACTS:

Ing. Lukas Havlik
Kovosvit MAS Machine Tools, corp., Sezimovo Usti,
Czech Republic
+420 381 632 427, havlik@kovosvit.cz